

## **The Effect of Leadership Styles and the Mediating Role of the Quality of Work-Life on Employee Job Performance in Vietnamese Enterprises in Ho Chi Minh City**

**Khanh Tuan VUONG**

*Malaysia University of Science and Technology  
Block B, Encorp Strand Garden Office, No. 12, Jalan PJU 5/1, Kota Damansara,  
47810 Petaling Jaya, Selangor Darul Ehsan, MY  
vuong.tuan@phd.must.edu.my*

**Sundry RAJAGOPAL**

*Malaysia University of Science and Technology  
Block B, Encorp Strand Garden Office, No. 12, Jalan PJU 5/1, Kota Damansara,  
47810 Petaling Jaya, Selangor Darul Ehsan, MY  
sundry@must.edu.my*

**Harwindar SINGH**

*Malaysia University of Science and Technology  
Block B, Encorp Strand Garden Office, No. 12, Jalan PJU 5/1, Kota Damansara,  
47810 Petaling Jaya, Selangor Darul Ehsan, MY  
drharwindar@must.edu.my*

**Premkumar RAJAGOPAL**

*Malaysia University of Science and Technology  
Block B, Encorp Strand Garden Office, No. 12, Jalan PJU 5/1, Kota Damansara,  
47810 Petaling Jaya, Selangor Darul Ehsan, MY  
premkumar@must.edu.my*

**Abstract.** *Employees' satisfaction at work plays an essential role in enterprises performing effectively and sustainably developing. Encouraging and creating a professional work environment for employees to have favorable working conditions are necessary for helping them prove their abilities. Therefore, this paper analyses the leadership styles (LS) and the mediating role of quality of work-life (QWL) towards employee job performance (EJP). The researcher collected 401 samples in Ho Chi Minh City to analyze and verify the research model. From the findings, it is evident that there is a significant relationship between the LS and the mediating role of QWL towards EJP. Based on the results of the empirical study, the researcher recommends that administrators and scholars refer to and study this result in planning the managerial policies in human resources to help employees feel satisfied with their jobs.*

**Keywords.** *human resource development; leadership style; quality of work-life; employee job performance; Vietnam.*

## **Introduction**

Human resources play a vital role in creating values for any organization. Human resources management theories have proved that employees become valuable when they can create value for firms (Mai & Dang, 2015). The quality of work life is considered as the foundation, determining the degree of satisfaction and attachment to an organization (Fatmasari, Al, & Wulida, 2018). The quality of work-life (QWL) helps employees work joyfully and effectively. Therefore, within value created for the organization, human resources are the vital factor, and it needs to be concerned thoroughly.

Moreover, in the 21st century, globalization was said to force the economy to evolve towards services and information technologies. This change made employees an organization's most valuable asset (Narehan, Hairunnisa, Norfadzillah, & Freziamella, 2014). In addition, to achieve business success, there are several critical factors, such as leadership skills, related to environmental impact, but the most crucial element is human resources (Mai & Dang, 2015). Therefore, the focus of human resource development is to develop the most superior workforce to aid the organization's successive growth (Kulkarni, 2013).

Furthermore, for employees to work effectively, the role of leaders is vital. Doing business in a competitive environment, regardless of the field of production or service, requires leaders to have a clear vision and direction to maintain and develop their organization (Mai & Dang, 2015). Meanwhile, a leader focuses on standards, values, needs, and abilities and follows them positively to motivate employees. An effective leader can instruct employees to follow the right track by understanding their needs and ambitions, and a leader can perceive the employees' thoughts and expectations to encourage them to work effectively. Businesses must recognize that a motivated, stable, and sizable workforce can deliver power to a firm's survival (Mai & Dang, 2015). Therefore, it is wise to inspire employees' passion by applying a leadership style (LS) that affects employees' performance. Based on the above factors, this empirical study investigates the effect of LS with the role of quality of work-life (QWL) on improving employee job performance (EJP) in enterprises in Ho Chi Minh City.

## **Literature review**

### ***Employee job performance***

For an enterprise to do business effectively, it must have professional staff, and they must work to bring back values to the organization. Nowadays, employees' motivation is considered as one of the most important factors in achieving success and prosperity in business within such a dynamic and fierce market competition (Mai & Dang, 2015). Therefore, employees are considered as the fulcrum of the lever, since they can have a significant influence on sale turnover and the benefits to the enterprise; for this reason, numerous studies have launched procedures to assess employees' performance (Shaikh, Tunio, & Shah, 2017). In addition, the role of human resources is significant to any

enterprise. When employees work effectively, that enterprise develops sustainably and increases its competitive advantage.

Bambale, Kassim, and Musa (2016) have regarded performance as a multi-dimensional concept. Employee performance can be understood as an employee being able to create an outstanding result, exceeding the enterprise's expectation. Many factors affect employees' performance, and it will also highlight how these variables affect other elements in the workplace (Saeed et al., 2013). Performance is considered an art to complete a task, but this paper studies it again within some defined boundaries. Task performance is related to an individual's proficiency: an employee performs activities that contribute to the organization's technical core. This contribution can be both direct and indirect (Bambale, Kassim, & Musa, 2016). Furthermore, employees' performance is considered to be the overall outcome or success of a person during specific periods of duty which are compared to the standard of work and the targets or criteria that were predetermined and agreed upon (Rivai, 2004; Pawirosumarto, Sarjana, & Gunawan, 2017). Therefore, employee performance needs to be studied and applied to aid enterprise development in the context of present-day competition.

Employees' performance is considered their EP at the workplace as well as an essential component of the organization's success (Shaikh, Tunio, & Shah, 2017). Performance management must examine how outcomes are attained because this provides the necessary information to understand what is required to reach these outcomes (Shaikh, Tunio, & Shah, 2017). Therefore, from the above analysis, employee job performance can be followed and measured to determine whether employees have an enthusiastic working spirit, feel satisfaction, and bring value through efficiency and effectiveness at work when working for enterprises.

### ***Leadership styles***

The concept and definition of Leadership styles (LS) are understood differently from one person to another (Obiwuru, Okwu, Akpa, & Nwankwere, 2011). Leaders with excitement, enthusiasm, and energy are likely to similarly energize their followers, but leaders who feel distressed and hostile are likely to negatively activate their followers (Bambale, Kassim, & Musa, 2016).

Each individual has his or her perception of LS in a different context. Leadership is regarded as a significant study topic in management (Kalsoom, Khan, & Zubair, 2018; Odumeru & Ifeanyi, 2013; Weihrich, Cannice, & Koontz, 2008). When leaders have a suitable LS, it helps the enterprise be successful more easily. Therefore, LS is evaluated as an essential factor in the intense present-day competition to help motivate employees at work, so they can contribute to the enterprise's competition and sustainable development.

Leadership is also considered one of the important determinants closely related to any organization's success and failure (Khajeh, 2018). According to Kirkpatrick and Locke (1996), and Awamleh (2004), some critical organizations' outcomes have been closely associated with these LSs, such as satisfaction, the performance of the organization, group performance, and commitment. Moreover, LSs are considered the process of convincing or modeling for subordinates to lead the group to follow

the set targets. Therefore, if the LS is suitable for the organization or enterprise, it helps that enterprise to move in the right direction and vice versa.

Khajeh (2018) has regarded LS as a combination of different characteristics, traits, and behaviors, which were used by leaders to interact with their subordinates. Furthermore, LS is the way employees are directed and motivated by a leader to achieve the organization's goals. However, there are many different definitions and concepts of LSs, which include some opposite ones and neutral ones. Leadership style is a form of an individual's behavior performed when trying to use his or her influence on other subjects by that person's perception. When discussing the present LS, there are many different opinions. Hypotheses and private theories form these styles. Each person chooses his or her LS based on a combination of factors such as beliefs, values, and related private standards. On a higher level, there are other factors such as firm culture and the general standards in a general structure; there may be a suitable style that is supported. However, there is also another style which is not appropriate and is not supported.

Moreover, LS is a method for leaders to reach their targets; it deeply affects members as well as enterprise performance. This depends on the leaders' opinions as well as their LS choices. According to different situations, a leader can apply the most suitable style. However, there is no correct method for all leaders. Each leader usually combines many different styles which depend on different situations and the nature of the task. Therefore, this paper analyses the critical LSs with four characteristics as described in the following sections.

### ***Transactional leadership***

Transactional leadership is regarded as the managerial LS concerning the role of supervisors, organizations, and group activities. A transactional leader is understood as the person who enacts changes in the procedures between the leader and followers. Transactional leadership focuses on three main backbones by inspiring employees, building employees' vision, caring for each individual, and challenging their intellect. Transactional leadership is said to be based on the exchange process, in which the leader manages the rewards and sanctions (Awamleh, 2004). This LS can collect the necessary followers and evaluate the levels required for that change as well as discuss assignments by targets and duties.

By administering rewards and recognition or punishment, transactional leaders can motivate their employees to efficiently meet the objectives of the firm (Kalsoom, Khan, & Zubair, 2018; Odumeru & Ifeanyi, 2013). Leaders with a transactional style clearly build a working frame, from which the subordinates know what they are required to do and which rewards they will receive after completing that task. The punishment is not described in detail, but the participants in the leading system understand this reward and punishment system, which is strictly maintained by their leader.

Moreover, when a leader by the transactional style assigns tasks for the subordinates, employees receiving jobs are considered to be responsible for their duties, regardless of having the resources or necessary ability to complete the task. If there is an error, that

subordinate will be responsible for those errors and cope with punishment or the reward when doing well. Therefore, the employees will understand how they are when they achieve positive results or vice versa.

### ***Transformational leadership***

James MacGregor Burns (1978) conceptualized the transformational LS (Khan, Tufail, Qadir, & Khan, 2016) by guessing employees' motivations, not only external factors such as salary and the right working conditions but also internal ones such as being evaluated and responsibility at work. The transformational LS causes the subordinates to perceive the importance of their tasks for the enterprise and to perform those tasks well to reach the organization's set targets.

Khan et al. (2016) have stated that transformational leadership can connect one or more persons with others so that leaders and employees can raise the staff to higher levels of motivation and morality. A transformational manager can make the subordinates perceive their individual needs to develop individually and complete their jobs. In addition, transformational managers create their motivations and encourage the subordinates to work for the organization's far-reaching benefits, not only for increasing private profits. It can be seen that a LS following this method can help employees have self-control spirit, motivation for creativeness, and maximize their potentials.

Moreover, transformational leaders are considered leaders who positively foresee future scenarios for their organizations, primarily engaging in improving employees' self-confidence while helping them realize their potential, communicating an achievable mission and vision of the organization to employees, cooperating with employees to identify their needs, and collaboratively working to satisfy their needs (İşcan, Ersari, & Naktiyokc, 2014; Peterson, Walumbwa, Byron, & Myrowitz, 2009).

Transformational leaders whose engagement is required for organizational performance and the implementation of innovation greatly influence their employees (İşcan et al., 2014). This study focuses on the role of the LS in an organization's performance and innovation. Transformational managers can help their subordinates believe in their senior managers, have high motivation, and organize to reach a personal target, which also helps enterprises achieve success. In addition, transformational leaders can motivate their followers by instilling confidence in them and encouraging them to implement new ideas and techniques in their tasks (Kalsoom, Khan, & Zubair, 2018). Therefore, transformational leaders help their employees have a comfortable working spirit. Transformational leaders participate in supporting and encouraging their employees' spirits and helping them to progress and develop in their jobs.

### ***Democratic leadership***

Democratic leadership is an LS in which subordinates are recognized for their authority, and the leader has to carry out the subordinates' decisions. According to Bhatti, Maitlo, Shaikh, Hashmi, and Shaikh (2012), a democratic leader must make the final decision by inviting other members of the team to contribute to the decision-making process. This contribution not only increases job satisfaction by involving employees or team

members in what happens, but it also helps to develop employees' skills. Employees and team members can feel like they can control their destiny, such as the promotion that they deserve and their motivation to work hard more than just for a financial reward.

The LS according to the mode of democratic leadership presents the opportunity for all staff to cooperate as a team and respect the team's decision. Knowledge and the understanding of the inner strengths and weaknesses of members in an organization are beneficial to the manager and the firm's success (Mai & Dang, 2015). Therefore, understanding the strengths and weaknesses of employees and assigning them suitable tasks as well as democratically handing over authority to employees helps them develop their intelligence of the working process.

In the democratic LS, leaders need to have creativity, a highly companionable spirit, and the ability to solve problems with a larger-scale, long-term vision, a modest attitude, a readiness to study, communication skills and other positive aspects to effectively carry out the leading role. The leader following this LS must be democratic, permit the subordinate to have free creativity, and presents solutions freely; the leader only watches, recommending and giving conditions for employees to develop. From that, it helps employees work more effectively and brings high value back to the enterprise.

### ***Laissez-faire leadership***

The French term *laissez-faire* is widely used in economics and political issues to define a policy towards the government's interference in the individuals' economic affairs and society (Ekmekci & Tosunoglu, 2016). The *laissez-faire* style of leaders permits their members in the group more freedom in completing tasks and setting time limits. Leaders provide support with all sources and the necessary advice for the subordinate's individual work, but the leader does not participate in it. For this reason, it also allows employees freedom in working, and they only pay attention to the results.

In leadership literature, *laissez-faire* is related to a 'hands-off, let things ride' approach toward individuals in the workplace (Ekmekci & Tosunoglu, 2016). *Laissez-faire* is also regarded as the mandated LS in which leaders pass their responsibility to members of the group to make their own decisions. *Laissez-faire* leadership is also considered the absence of a leader.

Bass and Avolio (1997) have described *laissez-faire* leadership as an ineffective method when accompanying active corrective leadership, which monitors and pays attention to mistakes while passive corrective leadership involves waiting for things to go wrong before intervening. However, when managing staff with high education in a developed society, LS usually follows the school of *laissez-faire*, which will allow the highly educated staff the freedom to work, and it gives them the freedom to create as well as bring value back to the enterprise. Therefore, this LS is also considered and applied to enterprises. *Laissez-faire* leadership can be essential in the new era when employees are trained basically and have much knowledge. They tend to favor freedom, self-control their work, and reporting the results to their superior.

### ***The concept of quality of work-life***

All employees want to work in a comfortable environment, to have freedom, and to not be forced, while leaders expect to increase productivity and working performance and to manage the business effectively. Meanwhile, QWL is no longer considered to be a new issue in organizations because most past studies have proved that QWL was the most important priority that all organizations considered (Narehan, Hairunnisa, Norfadzillah, & Freziamella, 2014). In addition, to create a friendly work environment, enterprises must build clear regulations for limited interests and each person's responsibility. They also have clear reward and punishment policies and a professional work environment.

Quality of work-life signifies the level to which the organization's members can satisfy their essential needs through experience in that organization (Chib, 2012; Fattahi, Kazemian, Damirchi, Kani, & Hafezian, 2014). Quality of work-life is also related to the extent to which employees can be satisfied with their personal and work needs when they participate in the workplace while working towards the organization's goals (Swamy, Nanjundeswaraswamy, & Rashmi, 2015). Quality of work life is concerned with the importance of rewards for employees in their workplace so that the organization can give employees a superior QWL (Fatmasari, Al, & Wulida, 2018). Based on the above analysis, it is clear that QWL plays a vital role in creating motivation for employees to work. A qualified work environment creates a comfortable spirit for employees so that they can work more effectively and dedicate themselves to the firm for a long time.

### ***The relationship between leadership styles and the quality of work-life***

Leadership style is considered the set of a leader's features that influences the subordinates so that the organization's goals can be achieved (Pawirosumarto, Sarjana, & Gunawan, 2017). In addition, the organization's performance is a symbol of its ability to efficiently achieve an individual's objectives (Shaikh, Tunio, & Shah, 2017). Based on the analysis, the leader must help the employees feel passionate about their work and develop their strong points. Each leader and manager must understand his or her employees' requirements, needs, and expectations as well as create a suitable work environment to motivate the employees (Mai & Dang, 2015). Therefore, the LS is essential to helping employees work more effectively to develop the enterprise. In other words, the LS affects the QWL of the enterprise.

Moreover, the ability of the management to operate through a 'collaborated effort' depends on the leadership's capability (Obiwuru et al., 2011). The leader's duty is to help the employees perceive that the work they perform is suitable to their profession and skills and to help them develop their expertise in the future and dedicate themselves to the enterprise for a long time. To be an efficient leader, a leader should be able to identify what type of LS is suitable to apply in the company to motivate and discipline the employees in the company (Pawirosumarto, Sarjana, & Gunawan, 2017). An effective LS creates benefits for the enterprise, encourages members to reach the targets, benefits that they expect, and maintains a positive reputation for the firm. According to Mai and Dang (2015), employees' motivations should be combined with the employees' needs and expectations which are created from work and the workplace factors that motivate the employees. Therefore, the LS and employees' performance are mutually supplemented to help enterprises develop. When the leader has an effective LS, it helps

the employees have enthusiasm about working, creating values for the enterprise, and helping the enterprise to obtain positive results in manufacturing activities and business.

### ***The relationship between quality of work-life and employee job performance***

There is a relationship between the QWL and EJP. The term 'quality of work-life' was presented in many research journals in the 1970s (Kulkarni, 2013). In addition, QWL depends on a combination of variables in the work environment, as it has an essential impact on an organization's commitment, work participation, and job performance (Hashempour, Ghahremanlou, Etemadi, & Poursadeghiyan, 2018). Narehan, Hairunnisa, Norfadzillah, and Freziamella (2014) have stated that organizations should commit to QWL to make improvements in their organizations, so they will be favorable and offer useful jobs and a pleasant work environment to employees at the organization, while it requires efforts through the active participation of the staff throughout the organization during the work process.

'Decent' income levels are affected by declining wage share, rising inequality, and the recently increased cost of living around the world beyond minimum subsistence or market-clearing rates (Christian, Jance, James, & Stuart, 2017; Werner & Lim, 2016). Furthermore, due to changes in the work environment, such as the technology, high competition, and the rise of employee unions, employers are not only offering compensation, but they are also considering other benefits, both intrinsic and extrinsic, to create a quality work environment that will attract and retain the best brains in the industry (Fattahi et al., 2014). Therefore, in the changing era, QWL requires enterprises to supply their employees with not only suitable materials and salaries but also a friendly work environment and comfortable working spirit, so that they can be motivated to work and develop all their abilities.

Furthermore, QWL is regarded as an essential factor affecting job satisfaction at work (Fattahi et al., 2014). Quality of work-life programs has two objectives: to enhance employees' productivity and to enhance their satisfaction (Fattahi et al., 2014). Quality of work-life not only relates to salary issues but also conditions of employment, private conflicts, the pressure at work, lack of freedom, and challenging tasks (Kulkarni, 2013). Therefore, QWL is considered to bring both valued materials and spirits back to the workforce. According to Kulkarni (2013), QWL includes proper equal compensation, working conditions with safety and health care, opportunities for promotion to develop human capacities, continuous development and security, social integration, and constitutionalism in the workplace. These factors are the basics of QWL for employees so that they can help them have a positive work environment and develop their abilities.

There are many different opinions about employees' perceptions of QWL. However, the professional work environment is still a work environment where enough and higher conditions and the requirements of employees' tasks can be met. In that place, there needs to be cooperation between managers and employees. All employees need to be valued, and they should apply collective attempts in the labor market every time (Kulkarni, 2013). Therefore, enterprises must build a comfortable, friendly work environment for employees. Quality of work life is the quality of the content of the



relationship between employees and their total work environment, with human dimensions added to the usual technical and economic ones (Kulkarni, 2013).

Based on the above analysis, there is a close relationship between QWL and employee job performance. When companies improve the QWL, it helps employees work comfortably. For this reason, they work more effectively and have a strong attachment to the organization. An effective leader and a professional work environment affect employees' performance at work.

## Research methodology

This study was based on previous studies to develop the characteristics of issues and provide analysis to Vietnamese enterprises in HCMC. After viewing material related to earlier studies, the researcher applied these concepts to develop the scales of measurement. Some scales of measurement were based on previous studies, or the researcher adjusted them by the researcher's own subjective opinion and then analyzed the reliability of the scales of measurement after collecting samples. The Likert scale was designed with five degrees: From 1 (completely disagree) to 5 (completely agree).

The study was conducted in HCMC with 401 good samples after rejecting the unsuitable samples to input and analyze the data. The study examined Cronbach's alpha, exploratory factor analysis (EFA), confirmatory factor analysis (CFA), and structural equation modeling (SEM) to verify the research model. After that, the researcher provided solutions and suggestions based on the results.

## The conceptual framework and hypothesis of this study

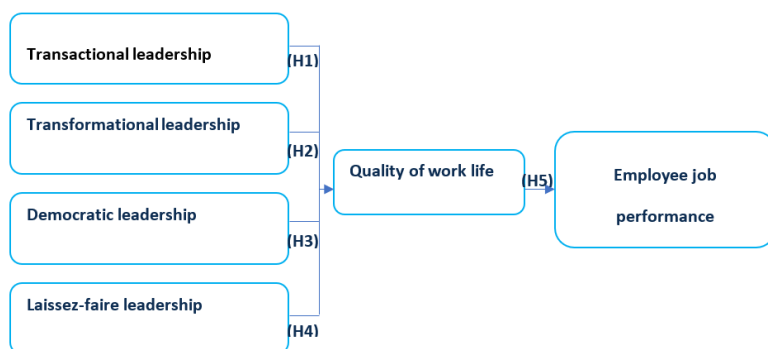

**Figure 1. The conceptual framework**

## Hypothesis

H1: There is a significant relationship between Transactional leadership and Quality of work-life towards Employee Job performance.

H2: There is a significant relationship between Transformational leadership and Quality of work-life towards Employee Job performance.

H3: There is a significant relationship between Democratic leadership and Quality of work-life towards Employee Job performance.

H4: There is a significant relationship between Laissez-Faire leadership and Quality of work-life towards Employee Job performance.

H5: There is a significant relationship between the Quality of work-life and Employee Job performance.

**Items included in the measurement scale**

*Table 1. Items included in measurement scale*

<b>Factors</b>	<b>Observed variables</b>	<b>Sources</b>
<b>Transactional leadership (TSL)</b>	TSL1: Creating motivation through rewards and punishment	
	TSL2: Instructing employees to work	
	TSL3: Orienting targets	
	TSL4: Empowering and suggesting duties	
	TSL5: Challenging employees through intelligence	
	TSL6: Building the managerial system	
	TSL7: Complementing directly when reaching the targets	
<b>Transformational leadership (TML)</b>	TML1: Idealised influence	Munir, Rahman, Malik, and Ma' Amor (2012)
	TML2: Inspirational motivation	Munir et al. (2012)
	TML3: Intellectual stimulation	Munir et al. (2012)
	TML4: Individualized consideration	Munir et al. (2012)
	TML5: Giving conditions for employees' creativeness	
	TML6: Giving out decisions based on ethical notions	
	TML7: Connecting the workgroup to work	
<b>Democratic leadership (DEL)</b>	DEL 1: Advice	Basit, Sebastian, and Hassan, 2017; Iqbal, Anwar, and Haider, 2015
	DEL 2: Decision making	Basit, et al., 2017; Jain and Chaudhary, 2015
	DEL 3: Shared	Basit, et al., 2017
	DEL 4: Consultation	Basit et al., 2017
	DEL 5: Involvement	Basit et al., 2017; Iqbal, Anwar, and Haider, 2015
	DEL 6: Self-perfecting at work	

	DEL 7: Innovating at work	
<b>Laissez-faire leadership (LFL)</b>	LFL1: Freedom	Basit et al., 2017; Jain and Chaudhary, 2015
	LFL2: Leadership barriers	Basit et al., 2017; Iqbal, Anwar, and Haider, 2015
	LFL3: Communicating properly	Basit et al., 2017
	LFL4: Expressing views	Basit et al., 2017; Jain and Chaudhary, 2015
	LFL5: Staying out of the way	Basit et al., 2017
	LFL6: Respecting all opinions	
	LFL7: Decision-based on the team's suggestion	
<b>Quality of work-life (QWL)</b>	QWL1: Satisfying the work	
	QWL 2: Satisfying the salary	
	QWL 3: Working effectively	
	QWL 4: Perceiving a positive work environment	
	QWL 5: Work culture is comfortable	
	QWL 6: Having chances for promotion	
	QWL 7: Having support from colleagues	
	QWL 8: Having good welfare policy	
<b>Employee Job performance (EJP)</b>	EJP 1: Effective performance	
	EJP 2: Comfortable spirit	
	EJP 3: Passion for tasks	
	EJP 4: Solving problems fast	
	EJP 5: Finishing tasks on time	
	EJP 6: Supporting colleagues	
	EJP 7: Feeling satisfied at work	

## Findings and discussion

From the analysis in Table 2, it is clear that the coefficient of Cronbach's alpha of factors exceeded 0.7, and there was no variable with the corrected item – the total correlation was less than 0.3. This observation means that the scale is reliable, so the researcher applied for the EFA.

**Table 2. Testing Cronbach's alpha**

Factors	Cronbach's alpha
QWL	0.930
TSL	0.908
TML	0.905
LFL	0.886
DEL	0.896
EJP	0.879

### ***Exploratory factor analysis***

From the result of EFA run in the software SPSS 20.0 with the collected data, the coefficient of Kaiser-Meyer-Olkin Measure of Sampling Adequacy (KMO) was 0.930 > 0.05, and Bartlett's test of sphericity produced the statistic meaning with a Sig. of 0.000 < 0.05; all observed variables have mutual correlations overall with the collected data. There were five factors extracted after analyzing the EFA; all the factor loadings were > 0.5, while the average variance extracted was 64.421 (> 50%). Therefore, the EFA was satisfied and met the requirement.

### ***Confirmatory factor analysis***

***Table 3. Indicators for the suitability of the model with the research data***

<b>Indicators</b>	<b>Value</b>
CMIN/DF	1.622
TLI	0.947
CFI	0.950
RMSEA	0.039

Table 3 indicates that CMIN/DF = 1.622 (< 2), TLI and CFI exceeded 0.9, and RMSEA = 0.039 (< 0.05), meaning that the model was significant. Therefore, the model was suitable for the theory and research data. To obtain significant results, the researcher considered more issues related to the reliability of the scales of measurement (Cronbach's alpha, CR, and AVE), convergent validity, and discriminant validity.

### ***Evaluating the reliability of the scale***

The reliability of the scales of measurement was evaluated using three indicators: composite reliability (CR), average variance extracted (AVE), and Cronbach's alpha coefficients. The scale was considered to be reliable when the synthetic reliability was > 0.5, and the total AVE had the meaning when validity was > 0.5 (Hair, Anderson, Tatham, & Black, 1992). Based on the results in Table 4 below, all CR and AVE were > 0.5, and the Cronbach's alphas of all factors were > 0.7. Therefore, all the scales are reliable.

The scales of measurement were considered to reach convergent validity when the standardized weights of scales were > 0.5 and had statistical meanings (Anderson & Gerbring, 1988; Hair et al., 1992). Moreover, one more criterion to test the convergent validity was AVE, as Fornell and Larcker (1981) have stated that for a factor to reach the convergent validity, AVE must be at least 0.5.

**Table 4. CR, AVE, and Cronbach's alpha coefficients**

Factors	Cronbach's alpha	Composite reliability (CR)	Average variance extracted (AVE)
QWL	0.930	0.931	0.633
TSL	0.908	0.909	0.589
TML	0.905	0.909	0.592
LFL	0.886	0.889	0.537
DEL	0.896	0.898	0.563
EJP	0.879	0.879	0.511

The result of testing the CFA model was examining the main characteristic of each scale, such as unidimensional, convergent validity, and discriminant validity. The composite reliability and AVE of each measuring component in the model were also evaluated.

The result of the analysis and evaluation revealed that all the scales achieved their validity and reliability. All the results of the CFA were suitable, since all the models of the CFA were suitable for the market data without any adjustments, and there was no case with the minus variance.

**Analyzing the Structural Equation Modelling (SEM)**

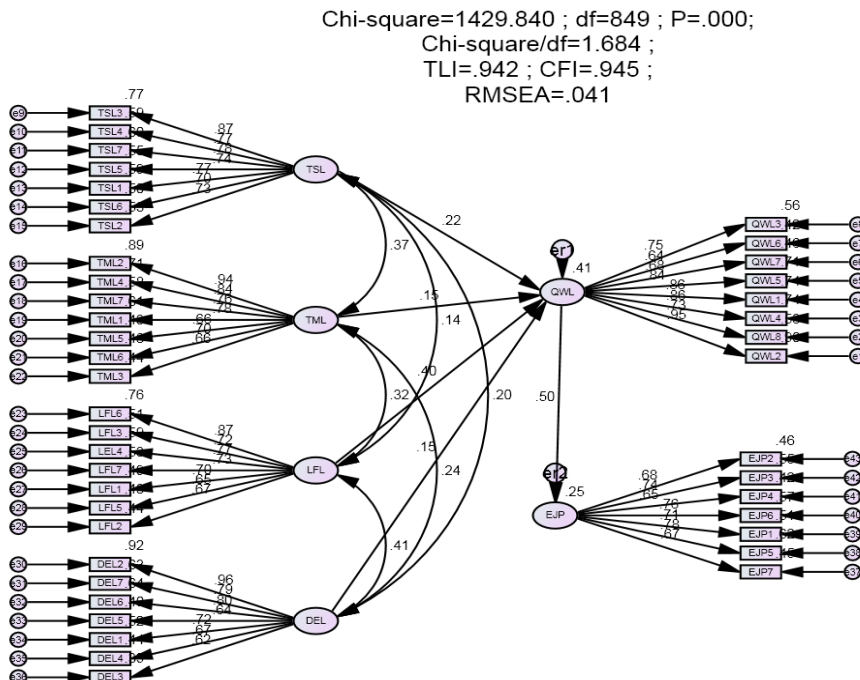

**Figure 2. The result of SEM analysis**

The result of the SEM analysis in Figure 2 indicates that the model is suitable with the research data as CMIN/df = 1.684 (< 2), TLI = 0.942 (> 0.9), CFI = 0.945 (> 0.9), and RMSEA = 0.041 (< 0.05). The SEM revealed that the estimated result of the parameters indicated that all the relationships had statistical meanings.

**Table 5. Regression weights: (Group number 1 - default model) unstandardized**

Regression weights: (Group number 1 - default model) unstandardized						
			Estimate	SE	CR	P
QWL	<---	TSL	0.196	0.042	4.648	***
QWL	<---	TML	0.153	0.048	3.215	0.001
QWL	<---	LFL	0.457	0.059	7.783	***
QWL	<---	DEL	0.122	0.040	3.096	0.002
EJP	<---	QWL	0.360	0.040	8.925	***

**Table 6. Standardized regression weights**

Standardized regression weights: (Group number 1 - default model)			
			Estimate
QWL	<---	TSL	0.218
QWL	<---	TML	0.155
QWL	<---	LFL	0.396
QWL	<---	DEL	0.147
EJP	<---	QWL	0.505

**Verifying the hypothesis**

Based on the P-values of the estimated parameters in Table 5, the hypotheses H1, H2, H3, H4, and H5 were all supported (P-values < 0.05). The cause and effect relationship from Table 5 indicated that transactional leadership (TSL), transformational leadership (TML), laissez-faire leadership (LFL), democratic leadership (DEL), all have a great positive influence on Quality of work-life (QWL), and the mediating role of QWL has a great positive influence on Employee Job performance (EJP).

**Conclusions and recommendations**

**Conclusions**

From the SEM analysis, it is clear that the mediating role of QWL, greatly and positively affected EJP. Meanwhile, the LS factor that strongly affected QWL towards EJP was LFL,

with  $b = 0.396$ . The second strongest factor affecting QWL towards EJP was TSL, with  $b = 0.218$ . The third factor affecting QWL towards EJP was TML, with  $b = 0.155$ . The fourth strongest factor affecting QWL towards EJP was DEL, with  $b = 0.147$ . In addition, the supporting factors of LSs and the mediating role of QWL have a great positive influence on EJP, with  $b = 0.505$ . This result means that if leaders in HCMC locations have efficient perception and apply the above LSs, especially LFL, as well as creating a positive work environment for employees, this will help improve the employees' performance at work.

### ***Recommendations***

The finding of this study has important implications for developing management and leadership theories. The researcher investigates factors such as TSL, TML, LFL, DEL, QWL, and EJP. It is evident, from the findings, that the key leading factors of leadership styles are: TSL, TML, LFL, DEL and, QWL became the mediating factor and has a significantly large effect on the EJP. Therefore, this finding can contribute to academic research about management and leadership theories. The outcomes of the study showed several factors such as the leadership styles and the mediating role of QWL are essential to improve an employee's job performance. Added outcomes from this study, is evidence to the administrators they can introduce, restructure and improve their overall management. This research will contribute to the sustainability of the enterprises in the new era.

The role of LS accompanied by QWL towards EJP is evident. Therefore, Vietnamese enterprises should pay attention to improving the leadership ability of managers, so that they can inspire and motivate the employees to work. Among the studied LSs, LFL was found to have the most substantial influence on EJP, and attention needed to be paid to inspire employees to work. It will help satisfy employees so that they will be dedicated to the enterprise's development in the international integration context. The findings indicated that the LS is a crucial concern to improve employees' performance.

To improve leadership competency in enterprises, the mediating role of QWL is also essential to enhancing employees' performance. Therefore, enterprises should pay attention to upgrading their work environments professionally for employees, as the work environment is considered the employees' second home where they spend 8 hours a day. Therefore, enterprises should focus on improving the work environment and building an enterprise culture such as a sharing spirit, supporting each other at work, etc. In addition, policies on compensation and benefits should be studied carefully and applied clearly for employees to understand the benefits that the firm provides to them. Moreover, the enterprises must illustrate a route of promotion for employees to be motivated about their career development. When the work environment is built professionally, employees are satisfied when they work. They are also attached and dedicated to the firm for a long time.

### ***Limitation***

Due to limited time, this paper features some limitations. The researcher used the convenience method of choosing samples to approach easily, collecting information from respondents so that the sample presentation was not correct, and not identifying the sampling error in the collection. Furthermore, the researcher only studied the

samples which were enterprises located in HCMC in different industries. The researcher did not study each distinguishing field, meaning that the findings still have limitations since the sample presentative is too general.

## References

- Anderson, J., & Gerbing, D.W. (1988). Structural Equation Modeling in Practice: A Review and Recommended Two-Step Approach. *Psychological Bulletin*, 103(3), 411-423. doi: 10.1037/0033-2909.103.3.411.
- Awamleh, R. (2004). The Impact of Transformational Leadership on Job Satisfaction and Self-Perceived Performance of Banking Employees: The Case of Jordan. *International Business & Economics Research Journal*, 3(11), 29-42. doi: 10.19030/iber.v3i11.3740.
- Bambale, A.J., Kassim, S.I., & Musa, L. (2016). Effect of Emotional Leadership on Employee Performance among Staff of Tertiary Institutions in Gombe. *Journal of Resources Development and Management*, 19, 23-30.
- Basit, A., Sebastian, V., & Hassan, Z. (2017). Impact of leadership style on employee performance (a case study on a private organization in Malaysia. *International Journal of Accounting & Business Management*, 5(2), 112-130. doi: 24924/ijabm/2017.11/v5.iss2/112.130.
- Bass, B.M., & Avolio, B.J. (1997). *Full range leadership development: Manual for the Multifactor Leadership Questionnaire*. Palo Alto, CA: Mind Garden.
- Bhatti, N., Maitlo, G.M., Shaikh, N., Hashmi, M.A., & Shaikh, F.M. (2012). The Impact of Autocratic and Democratic Leadership Style on Job Satisfaction. *International Business Research*, 5(2), 192-201. doi: 10.5539/ibr.v5n2p192.
- Chib, S. (2012). Quality of work-life and organizational performance parameters at workplace. *SEGi Review*, 5(2), 36-47.
- Christian, Y., Jance, P., James, A., & Stuart, C.C. (2017). The living wage as an income range for decent work and life. *Employee Relations*, 39(6), 875-887. doi: 10.1108/ER-03-2017-0071.
- Ekmekci, T.O., & Tosunoglu, H. (2016). Laissez-Faire leaders and organizations: how does Laissez-Faire leader erode the trust in organizations. *Journal of Economics Finance and Accounting*, 3(1), 89-99.
- Fatmasari, E., Al, M.M., & Wulida, A.T. (2018). The effect of quality of work-life and motivation on employee engagement with job satisfaction as an intervening variable. *Russian Journal of Agricultural and Socio-Economic Sciences*, 2(74), 108-114. doi: 10.18551/rjoas.2018-02.12.
- Fattahi, F., Kazemian, M., Damirchi, Q.V., Kani, B.K., & Hafezian, M. (2014). Quality of work life and employee's organizational commitment in sari city health center. *Journal of Research and Development*, 1(9), 12-20.
- Fornell, C., & Larcker, D.F. (1981). Evaluating Structural Equation Models with Unobservable Variables and Measurement Error. *Journal of Marketing Research*, 18(1), 39-50. doi: 10.2307/3151312.
- Hair, J.F., Anderson, R.E., Tatham, R.L., & Black, W.C. (1992). *Multivariate data analysis* (3<sup>rd</sup> ed.). New York, NY: Macmillan.
- Hashempour, R., Ghahremanlou, H, Etemadi, S., & Poursadeghiyan, M. (2018). The Relationship Between Quality of Work Life and Organizational Commitment of



- Iranian Emergency Nurses. *Health in Emergencies & Disasters Quarterly*, 4(1), 49-54. doi: 10.32598/hdq.4.1.49.
- Iqbal, N., Anwar, S., & Haider, N. (2015). Effect of leadership style on employee performance. *Arabian Journal of Business and Management Review*, 5(5), 1-6.
- İşcan, O.F., Ersarı, G., & Naktiyokc, A. (2014). Effect of Leadership Style on Perceived Organizational Performance and Innovation: The Role of Transformational Leadership beyond the Impact of Transactional Leadership - An Application among Turkish SMEs. *Procedia - Social and Behavioral Sciences*, 150, 881-889. doi: 10.1016/j.sbspro.2014.09.097.
- Jain, A., & Chaudhary, S. (2015). Leadership styles of bank managers in nationalized commercial banks of India. *Purushartha: A Journal of Management Ethics and Spirituality*, 7(1), 98-105.
- Kalsoom, Z., Khan, M., & Zubair, S.S. (2018). Impact of Transactional Leadership and Transformational Leadership on Employee Performance: A Case of FMCG Industry of Pakistan. *Industrial Engineering Letters*, 8(3), 23-30.
- Khajeh, E.H.A. (2018). Impact of Leadership Styles on Organizational Performance. *Journal of Human Resources Management Research*, 687849. doi: 10.5171/2018.687849.
- Khan, M.I., Tufail, M., Qadir, G., & Khan, S. (2016). Transactional Leadership, Transformational Leadership and Employee Engagement: A Case Study of Banking Sector. *The Discourse*, 2(2), 127-134.
- Kirkpatrick, S.A., & Locke, E.A. (1996). Direct and indirect effects of three core charismatic leadership components on performance and attitudes. *Journal of Applied Psychology*, 81(1), 36.
- Kulkarni, P.P. (2013). A literature review on training & development and quality of work life. *Journal of Arts, Science & Commerce*, 4(2), 136-143.
- Mai, N.K., & Dang, T.H. (2015). The Effects of Leadership Styles on Employee Motivation in Auditing Companies in Ho Chi Minh City, Vietnam. *International Journal of Trade, Economics and Finance*, 6(4), 210-217. doi: 10.7763/IJTEF.2015.V6.471.
- Munir, R.I.S., Rahman, R.A., Malik, A.M.A., & Ma'Amor, H. (2012). Relationship between Transformational Leadership and employees' job satisfaction among Academic staff. *Procedia - Social and Behavioral Sciences*, 65, 885-890. doi: 10.1016/j.sbspro.2012.11.215.
- Narehan, H., Hairunnisa, M., Norfadzillah, R.A., & Freziamella, L. (2014). The effect of quality of work life (QWL) programs on quality of life (QOL) among employees at multinational companies in Malaysia. *Procedia-Social and Behavioral Sciences*, 112, 24-34.
- Obiwuru, T.C., Okwu, A.T., Akpa, V., & Nwankwere, I. A. (2011). Effects of leadership style on organizational performance: A survey of selected small scale enterprises in IKOSIKETU Council development area of Lagos state, Nigeria. *Australian Journal of Business and Management Research*, 1(7), 100-111.
- Odumeru, J.A., & Ifeanyi, G.O. (2013). Transformational vs transactional leadership theories: evidence in literature. *International Review of Management and Business Research*, 1(2), 355-361.
- Pawirosumarto, S., Sarjana, P.K., & Gunawan, R. (2017). The effect of work environment, leadership style, and organizational culture towards job satisfaction and its implication towards employee performance in Parador

- Hotels and Resorts, Indonesia. *International Journal of Law and Management*, 59(6), 1337-1358. doi: 10.1108/IJLMA-10-2016-0085.
- Peterson, S.J., Walumbwa, F.O., Byron, K., & Myrowitz, J. (2009). CEO positive psychological traits, transformational leadership, and firm performance in high technology start-up and established firms. *Journal of Management*, 35(2), 348-368. doi: 10.1177/0149206307312512.
- Rivai, V. (2004). *Kepemimpinan dan Perilaku Organisasi*. Jakarta, ML: PT. Raja Grafindo Persada.
- Saeed, R., Mussawar, S., Lodhi, R.N., Iqbal, A., Nayab, H.H., & Yaseen, S. (2013). Factors Affecting the Performance of Employees at Work Place in the Banking Sector of Pakistan. *Middle-East Journal of Scientific Research*, 17(9), 1200-1208.
- Shaikh, M.R., Tunio, R.A., & Shah, I.A. (2017). Factors Affecting to Employee's Performance. A Study of Islamic Banks. *International Journal of Academic Research in Accounting, Finance and Management Sciences*, 7(1), 312-321.
- Suharno, P., Sarjana, P.K., & Muchtar, M. (2017). Factors affecting employee performance of P T. Kiyokuni Indonesia. *International Journal of Law and Management*, 59(4), 602-614. doi: 10.1108/IJLMA-03-2016-0031.
- Swamy, D.R., Nanjundeswaraswamy, T.S., & Rashmi, S. (2015). Quality of Work Life: Scale Development and Validation. *International Journal of Caring Sciences*, 8(2), 281-300.
- Wehrich, H., Cannice, M.V., & Koontz, H. (2008). *Management* (12<sup>th</sup> ed.). New Delhi, IN: McGraw Hill.
- Werner, A., & Lim, M. (2016). The ethics of the living wage: a review and research agenda. *Journal of Business Ethics*, 137(3), 433-447. doi: 10.1007/s10551-015-2562-z.

Received: October 8, 2019  
Accepted: December 11, 2019